



**NatSCA**

Natural Sciences Collections Association

<http://www.natsca.org>

## Journal of Natural Science Collections

---

Title: Flecs: a novel LEGO® tool for bound herbarium clamping

Author(s): Dupont, S., & R. Prakash

Source: Dupont, S., & R. Prakash. (2020). Flecs: a novel LEGO® tool for bound herbarium clamping. *Journal of Natural Science Collections*, Volume 7, 59 - 67.

URL: <http://www.natsca.org/article/2582>

---

NatSCA supports open access publication as part of its mission is to promote and support natural science collections. NatSCA uses the Creative Commons Attribution License (CCAL) <http://creativecommons.org/licenses/by/2.5/> for all works we publish. Under CCAL authors retain ownership of the copyright for their article, but authors allow anyone to download, reuse, reprint, modify, distribute, and/or copy articles in NatSCA publications, so long as the original authors and source are cited.

## Flecs: a novel LEGO® tool for bound herbarium clamping

Steen Dupont<sup>1,2</sup> and Raneer Prakash<sup>1</sup>

<sup>1</sup> Natural History Museum London, Cromwell Road, SW7 5BD London, United Kingdom

Received: 19<sup>th</sup> May 2019

<sup>2</sup> Corresponding Author: steen.dupont@nhm.ac.uk

Accepted: 10<sup>th</sup> Feb 2020

**Citation:** Dupont, S., and Prakash, R. 2020. Flecs: a novel Lego® tool for bound herbarium clamping. *Journal of Natural Science Collections*. 7. pp. 59-67.

### Abstract

A discussion of some of the current methods used for keeping herbaria volumes open during conservation and digitisation are discussed, and a solution to the physical challenges of digitising bound herbarium volumes with restricted opening capabilities is presented. The Flexible LEGO Clamping System (Flecs) is a collapsible page clamping system capable of holding open herbarium volumes with very restricted opening capabilities, while being versatile enough to deal with specimen position, volume thickness, volume position and repetitive use during mass digitisation.

**Keywords:** Botany, herbarium, imaging, conservation, digitisation, Samuel Browne, Hans Sloane

### Introduction

Digitisation of museum specimens has been a priority for natural history museums for decades, and for the past 5 years the NHM London has given digitisation new incentive through a dedicated Digital Collections Programme that is focused on the many challenges digitising an estimated 80 million specimens creates. A recent pilot project aimed at digitising late 17<sup>th</sup> century bound volumes of herbarium specimens collected by Samuel Browne from Fort St George, India (now part of Chennai). The volumes have a restricted degree of opening and the project resulted in a novel tool designed to hold herbarium volume specimen folios in place during digitisation, study and conservation.

The practice of collecting and preserving botanical specimens is surprisingly young compared to the history of botany. In a discussion on the origin of Herbaria (1885), Saint-Lager suggests one of the earliest examples of herbaria was the one used by Luca Ghini in Pisa in 1544. The primary argument for the late use of herbaria was the high price and

scarce availability of paper. Paper became affordable as a mounting material after the invention of printing in the mid fifteenth century (Saint-Lager, 1885). The invention of herbaria made plant specimens easily transportable allowing specimens from different localities or flowering periods to be compared and used as references which contributed significantly to the wealth of knowledge on the world's flora (Staern 1971). Through the efforts of some of the largest botanical collections in the world including New York Botanical Garden herbarium (NY), the Smithsonian National Museum of Natural History (US), the Paris herbarium (P), Naturalis (L), Royal Botanic Gardens Victoria (MEL), Royal Botanic Garden Edinburgh (RBGE), Royal Botanic Gardens, Kew (K) and the Natural History Museum London (BM) good progress has already been made on the imaging of herbarium sheets and the results of several large scale efforts are already accessible. Digitisation efforts to date however have mainly focused on loose herbarium sheets that lend themselves well to rapid digitisation



workflows (Thiers *et al.*, 2016). Bound herbarium volumes present a more complex challenge than that of loose sheets, but are as valuable in their own right, usually representing a single collector's effort in a time period or location, some volumes are historically important as even though they are pre-Linnaean, for example, the Hermann bound volumes and the Clifford Herbarium at NHM were used by Linnaeus to designate many new type specimens.

The NHM London has more than 650 bound herbarium volumes including the 265 herbarium volumes that make up the invaluable Sir Hans Sloane botanical collection. As part of the NHM London initiative to digitise its natural history collections the challenge of preserving and digitising historic herbarium volumes was addressed. Herbaria are experiencing rapid changes in the way collections are now managed and used: mass digitisation initiatives, focused either on entire herbaria or subsets of specimens, such as types, have revolutionised the way in which researchers are using herbarium collections (Carine *et al.*, 2018). There is an appetite for access to herbarium data, online open-access herbaria meets this, but digitisation speed lags behind, in part because we need innovation in techniques, tools and protocols for handling herbarium specimens. In this paper, we investigate the various methods of handling bound herbarium volumes and present a new tool: the flexible LEGO clamping system for herbarium volumes (Flecs), for holding open difficult to open folios.

Bound volumes can present a series of challenges for digitisation most of which are related to a combination of the volume binding, the fragile nature of individual folios and degradation and positioning of specimens. The same properties that make paper an appropriate mounting material (e.g. thin, stiff, breathable and with absorbing properties) also lead to inevitable conservation problems over time. The Samuel Browne collection that is bound in two volumes from 1692-1698 provides good examples of herbarium volumes that show the specific characteristics that are challenging to digitisation. The very limited opening of the volumes presents a specific challenge for both conservation, digitisation and research as access to the folios for inspection or for imaging is in many cases very restricted. The restricted opening and page drape of herbaria can in part also be explained by the volume binding itself. As is outlined by Conroy (1987) some of the problems faced with the use of extension guards with a stiff spine, which is what we see in Herbaria volumes, is that this binding type does not allow for the folios

to drape properly when the book is opened (Conroy 1987).

The solutions currently used to secure folios of bound volumes during conservation and imaging were considered prior to designing a novel solution. The methods used on books such as glass plates that press the underlying folio flat for imaging or the application of suction for page fixation are not ideal as there are delicate botanical specimens on the folio and on subsequent folios that could be damaged. Two other options, the polyethylene strip and the snake weight that, at first, looked viable unfortunately were not appropriated due to either the fragile nature of the specimens or because of the acute angle at which the herbarium volumes need to be held at during imaging.

A polyethylene strip that is fastened over the edge of the folio is appropriate for folios where botanical material does not extend to the edge of the folio. However, if there is a risk of the polyethylene strip coming into contact with the specimens on the folio there is risk of damage much like when using the glass plate.

A snake weight is a versatile and commonly used tool during conservation and book scanning. The snake weight is a row of lead weights or lead shot in a cloth sleeve that can be folded, draped or spread across a folio to distribute weight where necessary to keep a folio secure. Herbarium volumes with very restricted opening however have to lie with the spine flat and the folios near vertical during imaging. In this position, the snake weight cannot be draped over the folios without also touching the edges of the underlying folios which might cause damage.

Other solutions such as leaded weights or general clamps were not considered usable as the upright position of the book meant that folios were always at an angle creating a downward slope unsuitable for solutions that required a horizontal surface to be stable without sliding or falling off. Another approach frequently used during examination of volumes is to work in pairs (one holding the folio and the other taking notes/studying). However, this option may not be practical most of the times and in such cases, the Flecs is an efficient and practical tool.

To be able to work on and digitise herbarium volumes with a restrictive opening it is important that the mechanism used:

- is easy to apply during repetitive digitisation
- can accommodate the variability in specimen position on the folio

- can accommodate the variability in the thickness of the herbarium volume as folios are turned
- has a way of providing a variable amount of pressure depending on the nature of the volume
- is stable when used and will not damage the herbarium specimen during use.

We believe that the Flecs tool presented here addresses the challenges described above and is a novel way to manage volumes with restricted opening. We feel this tool is worth presenting to peers, librarians and academicians with manuscripts, rare books and historic volumes and hope they will find this useful and practical.

### Material and Methods

Critical to imaging herbarium volumes with a very restricted opening is achieving optimal imaging angles for the individual folios with specimens and associated data. The Browne herbarium volume spine and folios did not allow a proper spine throwback or folio drape to allow folios to settle when the book was opened. To alleviate these drawbacks a completely novel imaging setup with three innovative solutions was designed that

together enabled us to achieve an image of folios from as optimal a view as possible.

#### Camera positioning

To allow for the individual variation in drape that the volume folios expressed, the imaging camera was placed on a 5 axis support arm allowing the camera to be placed as parallel to the folio to be imaged as possible thereby reducing the folio skew in the image taken (Figure 1).

#### Spine pivot and adjustable book cradle

To compensate for the spine stiffness a new book cradle was developed. The new book cradle features a free spine support that allows the independent movement of the spine thereby increasing the book opening without applying any external pressures (Figure. 2). The newly designed book cradle was further positioned on a turntable that made it possible to rotate the book to image the opposite folio.

#### Flecs page clamps:

Prototypes and the final mechanism were made using LEGO (Figure 3), a modular toy that lends itself exceedingly well to prototyping as well as



Figure 1. The Herbarium Imaging Equipment (HerbIE) including DSLR camera (1), adjustable swivel arm (2), Flecs (3), Book cradle (4), and turntable (5).

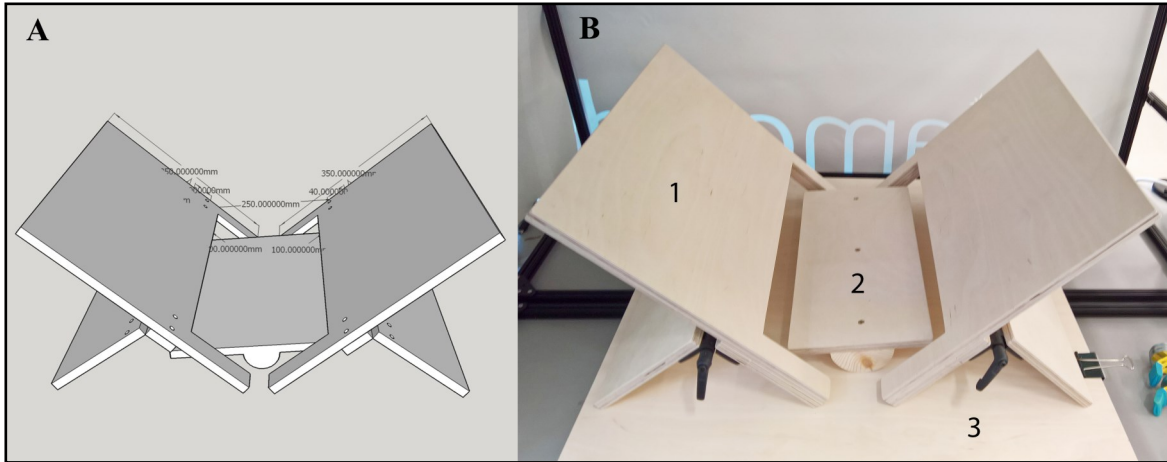

Figure 2. Herbarium volume cradle schematic (A) and actual model (B) including the book cover supports (1) tilting spine support (2) and a turntable base (3)

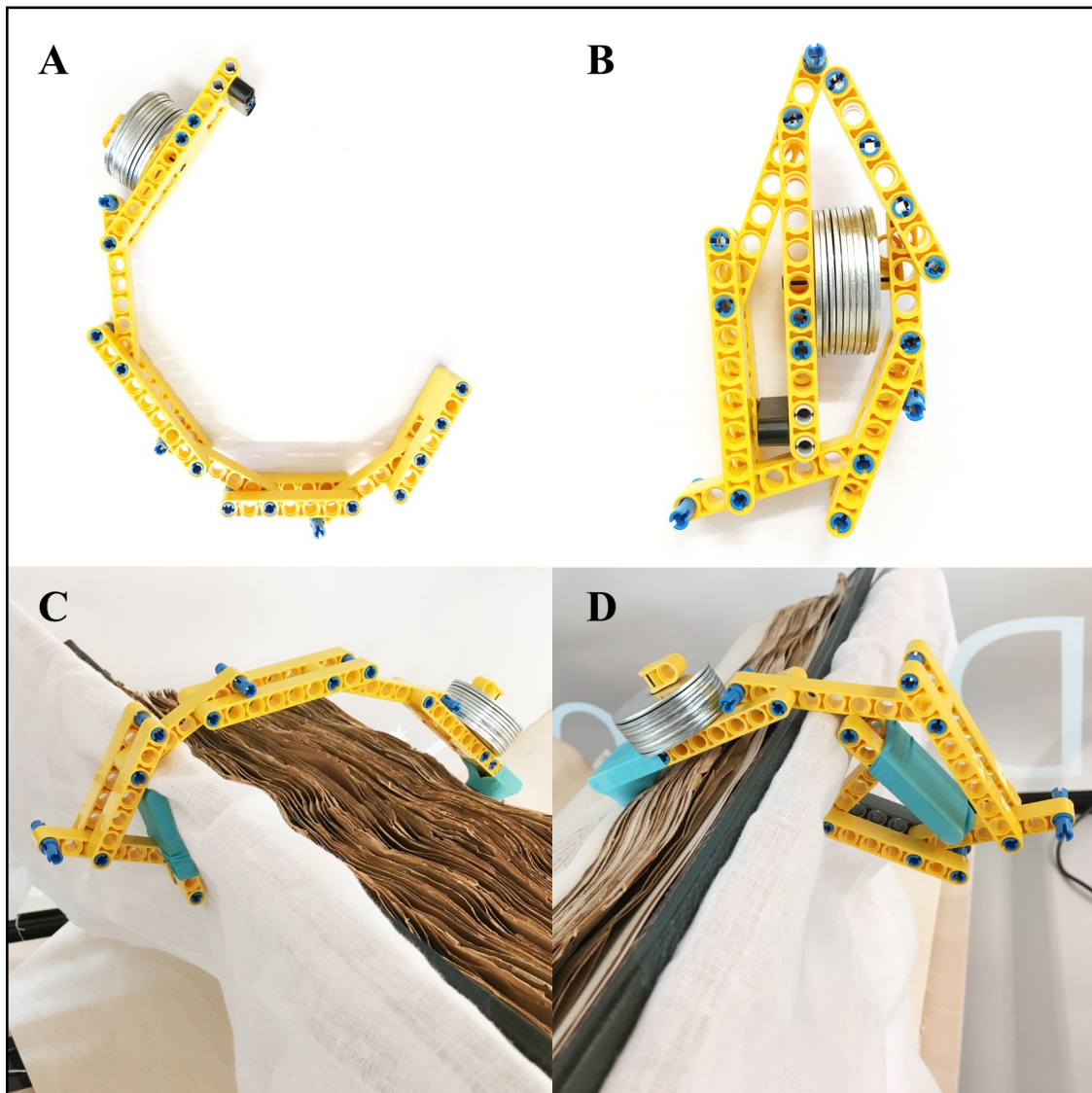

Figure 3. The Flexible LEGO clamping system (Flecs) shown in a fully extended position (A), compact position (B) and in two various clamping positions as used during imaging (C and D).

final product production (Dupont *et al.*, 2015). LEGO is made of acrylonitrile, butadiene and styrene (ABS) that is a hard durable plastic with good chemical resistance (Rutkowski and Levin, 1986) and was therefore not considered a risk to the folios or the specimens attached to them. In addition to the plastic LEGO bricks, 10 metal washers with M8 holes were used as weights and rubber sleeves made of lab grade rubber gloves were used to add friction to the mechanism. To finalize the design, create building instructions and generate a parts list the LEGO Digital Designer 4.2 (LEGO 2019) was used, the results of which can be seen in the supplementary material (Appendix 1). During the design process several curators and conservation technicians were regularly consulted on best practices for specimen handling as well as discussions of the use of materials that would come in to contact with the specimens.

### Results and Discussion

The Flexible LEGO Clamping System (Flecs) is made up of 32 technic pieces with an estimated cost of £6 (<https://www.lego.com/en-gb/service/replacementparts/sale>). For the sake of the discussion below the joint that is placed on the herbarium volume page is called the head and the joint that overhangs the book cradle is called the tail (Fig. 3A-B). For a complete parts list and assembly manual for the Flecs (see Appendix 1).

The mechanism was developed to emulate the versatility of the human finger and the way the fingers are used to hold open pages of a book by applying pressure and an outward directed frictional pull. To achieve both pressure and pull the Flecs was designed as a crescent that is rigid in its extended position, but collapsible at its six individual joints (Figure 3C). The location of the weights at the head ensures that, by changing the number of washers, a variable downward pressure can be applied while the crescent tail that overhangs the book cradle and the rubber sleeve at the head simultaneously produces an outward pull. The collapsible joints make it possible to adapt the Flecs to the varying distances between the herbarium volume cover and the open specimen folio (Figure 3D) depending on the position in the volumes of the folio being imaged. Furthermore, because the LEGO joints have enough friction to hold their positions, the Flecs can be shaped to lightly clamp the specimen folio and the book cradle thereby adding further stability.

The advantages of the Flecs when compared to currently used options is that the small footprint allows for the positioning of the mechanism on the

folio even if specimens extend to the folio edge. The small footprint also ensures that no other area of the volume (including the edges of the underlying folios) are touched and this reduces the potential of damage during digitisation where the folios are turned on a regular basis and the securing mechanisms are repetitively applied.

There are several possible improvements that can be made to the proposed mechanism and the Flecs could be considered a prototype, but we believe the same argument used by Dupont *et al.* (2015) applies here. The Flecs is a solution to a problem using a globally available modular tool that is cheap and simple to build without further tools or modifications which opens up for further improvements and testing by the library and academic community.

### Acknowledgements

Thank you to the Digital Collections Program at the NHM London and the Mercers Trust for providing funding and resources to work on the Samuel Browne volume pilot project. Thank you also to several colleagues including Vladimir Blagoderov, Ben Price and Helen Hardy for useful feedback and user testing. Invaluable feedback on specimen handling and conservation was given by Mark Carine, Konstantina Kantantiniduo and Mira Gogova. Thank you also to the reviewers for their time and effort which significantly improved the paper.

### References

- Carine, M.A., Cesar, E.A., Ellis, L., Hunnex, J., Paul, A.M., Prakash, R., Rumsey F.J., Wajer, J., Wilbraham, J., Yelilyurt, J.C., 2018. Examining the spectra of herbarium uses and users. *Botany Letters*, 165:3-4, pp.328-336.
- Conroy, T., 1987. The movement of the book spine. *Book and Paper Group Annual*. Vol 6.
- Desmond, R., 1977. *Dictionary Of British And Irish Botanists And Horticulturalists Including plant collectors, flower painters and garden designers*. CRC Press.
- Dupont, S., Price, B., Blagoderov, V., 2015. IMP: The customizable LEGO® Pinned Insect Manipulator. *ZooKeys* 481: pp. 131-138.
- LEGO, 2019. <http://ldd.lego.com>
- Meyer, E.H.F., 1791-1858. (1854/57). *Geschichte der botanik*. Königsberg pp. 268.
- Rutkowski, J.V., Levin, B.C., 1986. Acrylonitrile-butadiene-styrene copolymers (ABS): Pyrolysis and combustion products and their toxicity a review of the literature. *Fire and Materials*. 10 (3-4): p.93.
- Staern, W.T., 1971. Sources of information about botanic gardens and herbaria. *Biological Journal of the Linnaean Society*. 3: pp.225-233.
- Thiers, B.M., Tulig, M.C., Watson, K.A., 2016. Digitization of The New York Botanical Garden Herbarium. *Brittonia* 68(3): pp.324-333.
- Torrey Botanical Society. 1885. The Origin of Herbaria. *Bulletin of the Torrey Botanical Club*, 12(12), pp.129-131.

**Appendix I:** for Flecs: a novel LEGO® tool for herbarium clamping.







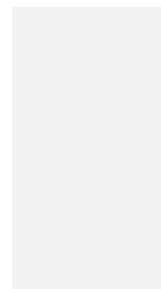
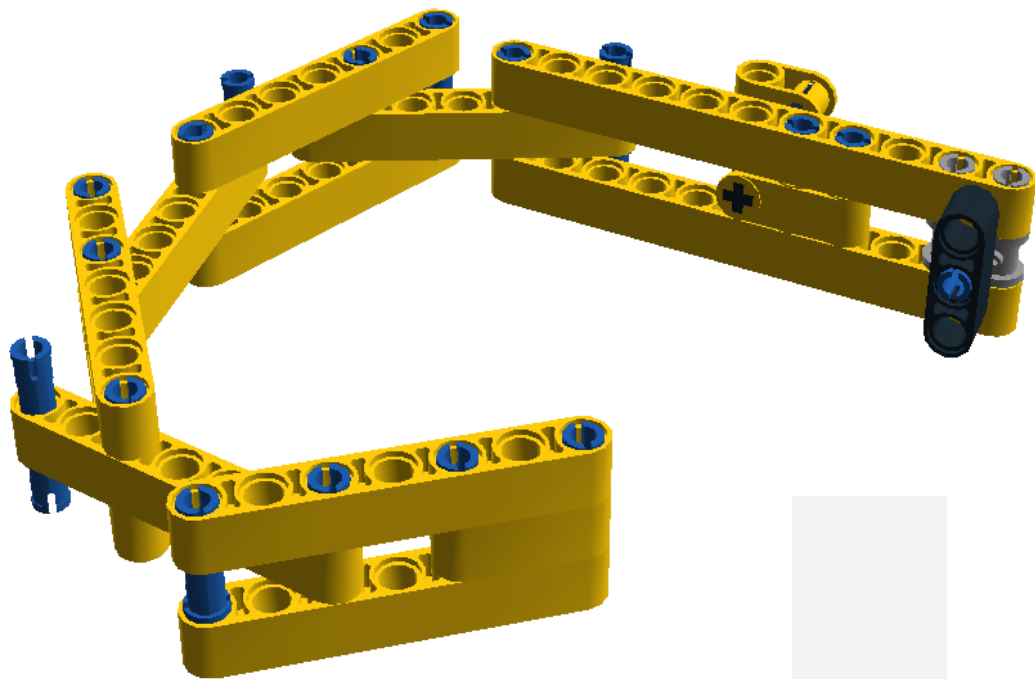





Model name: Flecs  
Number of bricks: 34

**Flecs finished model**



**Flecs components list:**

- |   |  |   |
|---|--|---|
| 1 x  4142822 TECHNIC 3M BEAM - Black                     | 1 x  4153707 TECHNIC 3M BEAM - Bright Yellow          | 9 x  4187082 TECHNIC 7M BEAM - Bright Yellow |
| 2 x  4174709 TECHNIC 11M BEAM - Bright Yellow            | 1 x  4189110 CONN BUSH W. ERIC/CROSSALE - Bright Blue | 1 x  370526 CROSS AXLE 4M - Black            |
| 16 x  4514553 CONNECTOR PEG W. FRICTION 3M - Bright Blue | 1 x  4107078 CROSS BLOCK 90° - Bright Yellow          | 1 x  4175441 CROSS BLOCK 3M - Bright Yellow  |
| 1 x  4211888 MODULE BUSH - Medium Stone Grey             |  |   |

**Step 1 of 12**

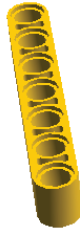

**Step 2 of 12**

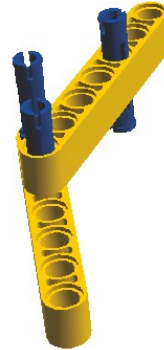
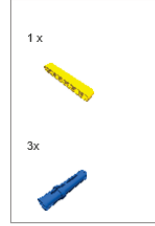

**Step 3 of 12**

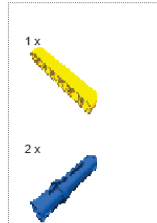

**Step 4 of 12**

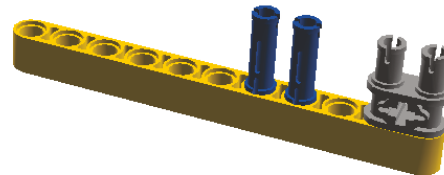
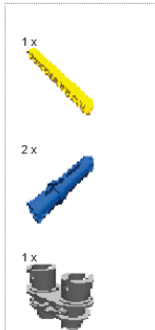



**Step 5 of 12**

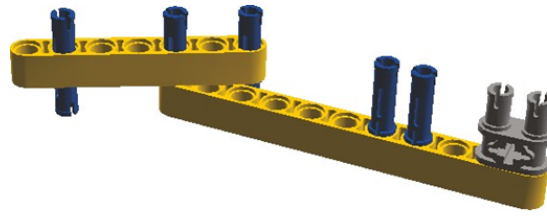
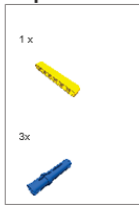

**Step 6 of 12**

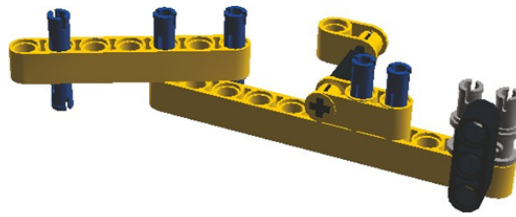

**Step 7 of 12**

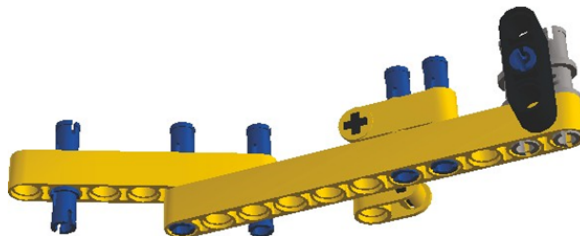

**Step 8 of 12**

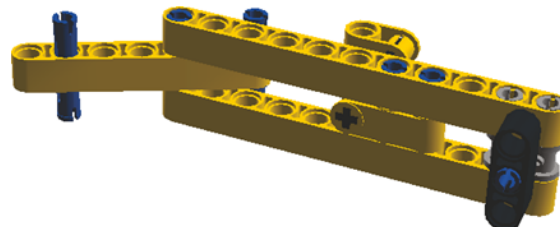
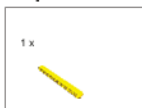

**Step 9 of 12**

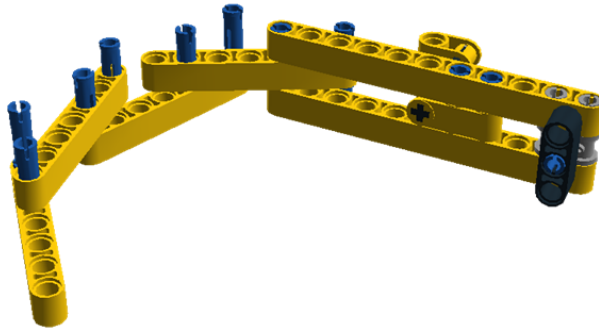

**Step 10 of 12**

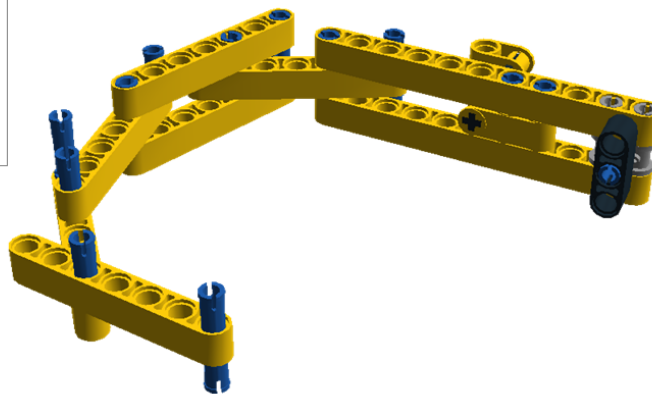
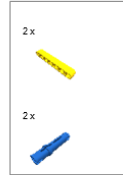

**Step 11 of 12**

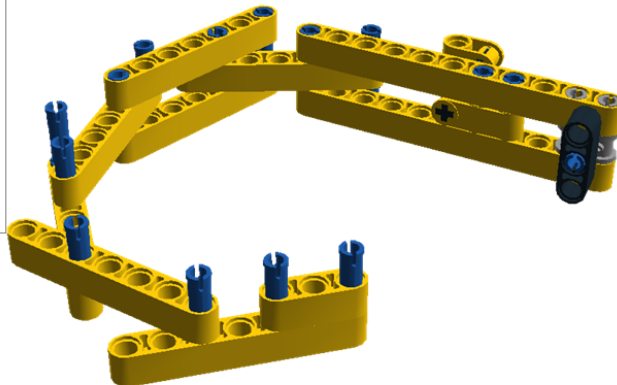
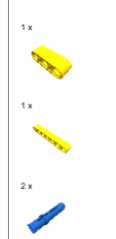

**Step 12 of 12**

